

See discussions, stats, and author profiles for this publication at: <https://www.researchgate.net/publication/277655906>

Influence of the Inter Teeth Volumes on the Noise Generation in External Gear Pumps

Article · January 2015

DOI: 10.2478/aoa-2014-0030

READS

6

1 author:



[Wieslaw Fiebig](#)

Wroclaw University of Science and Technol...

30 PUBLICATIONS 15 CITATIONS

SEE PROFILE

Influence of the Inter Teeth Volumes on the Noise Generation in External Gear Pumps

Wiesław FIEBIG

Institute of Machine Design, Wrocław University of Technology
Lukasiewiczza 7/9, 51-370 Wrocław, Poland; e-mail: wieslaw.fiebig@pwr.wroc.pl

(received April 16, 2013; accepted June 10, 2014)

The paper shows the new method for noise reduction in external gear pumps based on the analysis of the pressure in inter teeth volumes. The simulation model and measurement results of pressure changes in the inter teeth volume has been presented. Based on simulation results an additional volume has been obtained, which is connected to the inter teeth volume (decompression filter volume). Due this additional volume the build down processes in the pump are longer and the pressure overdue in the inter teeth volumes are smaller. This leads to the reduction of the dynamical excitation forces inside the pump and noise, especially in the higher frequency range.

Keywords: gear pumps, noise reduction, simulation, inter teeth volume.

Notations

κ – compressibility factor of the fluid [m^2/N],
 V_{Ri} – volume of the inter teeth space [m^3],
 A_{Si} – flow surface between the release grooves and the inter teeth volume [m^2],
 Q_{Ri} – flow in the part 1 or 2 of the inter teeth volume [m^3/s],
 α_D – flow coefficient,
 p_{Ri} – pressure in the part 1 or part 2 of the inter teeth volume [N/m^2],
 p_b – delivery pressure [N/m^2],
 p_s – suction pressure [N/m^2],
 ρ – density [kg/m^3],
 Q_{Li} – leakages (radial, axial gap) [m^3/s],
 Q_{RS} – flow between teeth [m^3/s].

1. Introduction

The pressure build down processes in external gear pumps are extremely fast in comparison with other displacement pumps and have a big influence on the excitation forces (FIEBIG, 1997; MANRING, KASARGADDA, 2003). To analyse the pressure build down processes in external gear pumps simulation models has been developed (CASOLI *et al.*, 2005; EATON *et al.*, 2006; ZADRIN *et al.*, 2004).

Based on the presented simulation model, the influence of the pressure release grooves geometry as well as the influence of the teeth geometry and other parameters of the inter teeth volume on the pressure build-down courses in the gear pump has been investigated.

2. Simulation of the pressure changes in inter teeth volumes

The model for the description of the pressure changes in the inter teeth volume has been shown on the Fig. 1. This model includes:

- inter teeth volume changes V_{R1} and V_{R2} depending from the teeth geometry and the angle position of the teeth,
- the changes of the flow surface A_{S1} , A'_{S1} and A_{S2} , A'_{S2} between the inter teeth volume and the pressure release grooves,
- the flow between teeth Q_{RS} and leakages between the inter teeth volume and the suction side Q_{Li} .

From the first point of the contact of the new teeth set A up to the point DP1 (symmetrical position to the central point C) the volume of the inter teeth volume decreases. During this time there is connection between the inter teeth volume and the delivery port. The volume is minimal for the angle position, in which the sealing points DP1 and DP2 are symmetrical to the central point C. From the symmetrical angle position defined on Fig. 1 the volume of the inter teeth volume increases up to the end of the teeth contact of the previous teeth set. During that time there is a connection between inter teeth volume and the suction port.

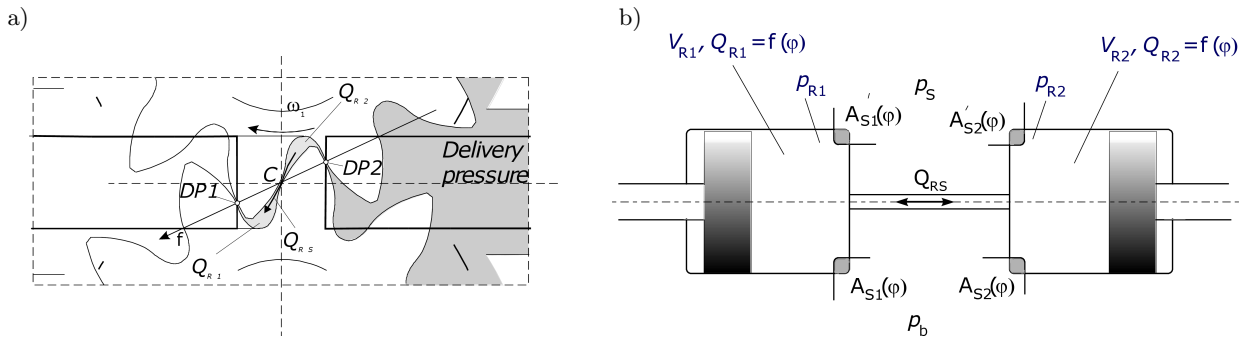

Fig. 1. Mathematical model of the pressure changes in the inter teeth volume.

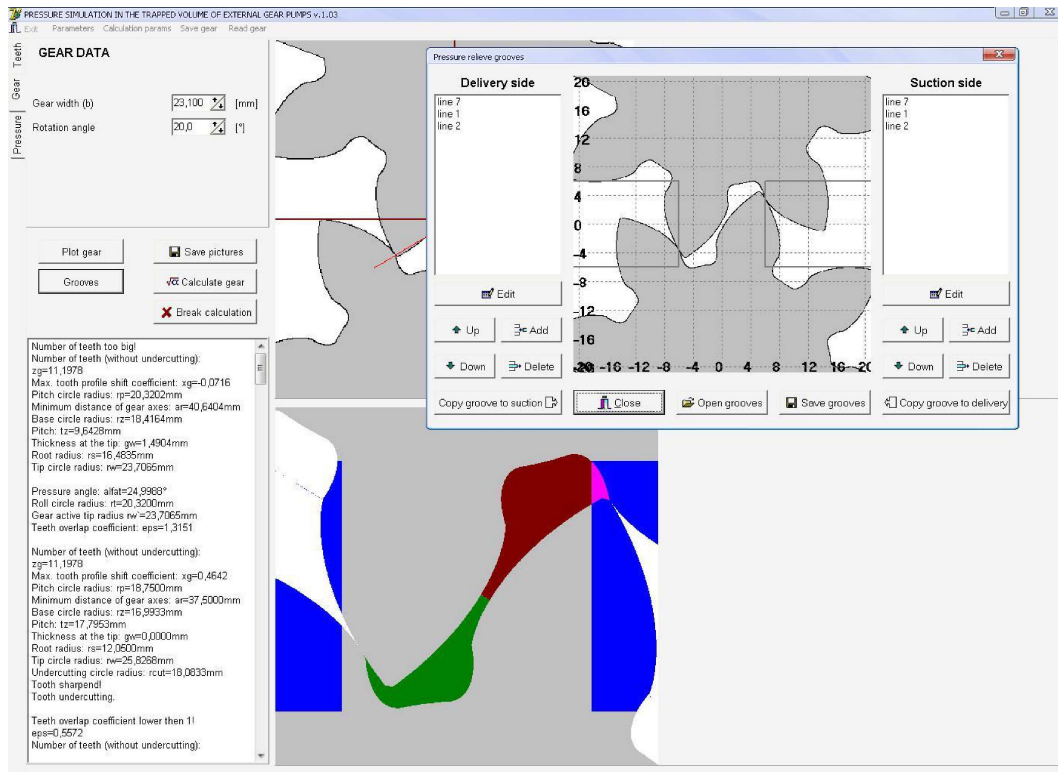

Fig. 2. Gear – the second module of the simulation program.

$$\frac{dp_{Ri}}{dt} = \frac{1}{\kappa \cdot V_{Ri}} \left(Q_{Ri} - A_{Si} \cdot \alpha_D \text{sign} \sqrt{\frac{p_{Ri} - p_b}{\rho}} - A_{Si} \cdot \alpha_D \text{sign} \sqrt{\frac{p_{Ri} - p_{Si}}{\rho}} - Q_{RS} - Q_{Li} \right). \quad (1)$$

Based on equation (1) the pressure courses in the inter teeth volume has been calculated. The input data in the simulation program are as follows:

- teeth geometry,
- geometry of the pressure release grooves,
- operational conditions of the pump.

In the second module of the program (Fig. 2) the parameters of the teeth/gears geometry will be checked and the pressure release grooves are modeled.

In this module also the pump operational parameters as in the Fig. 3 are entered.

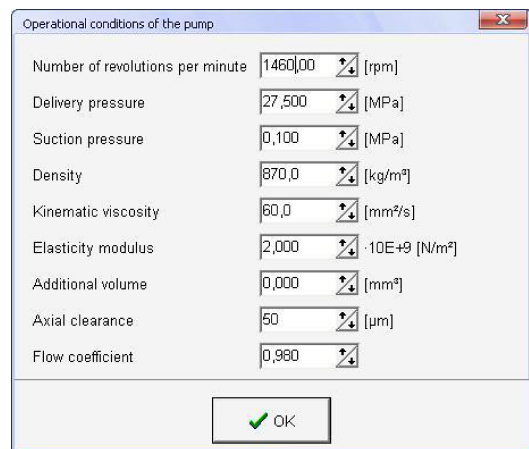

Fig. 3. Input of the operational parameters of the pump and fluid data.

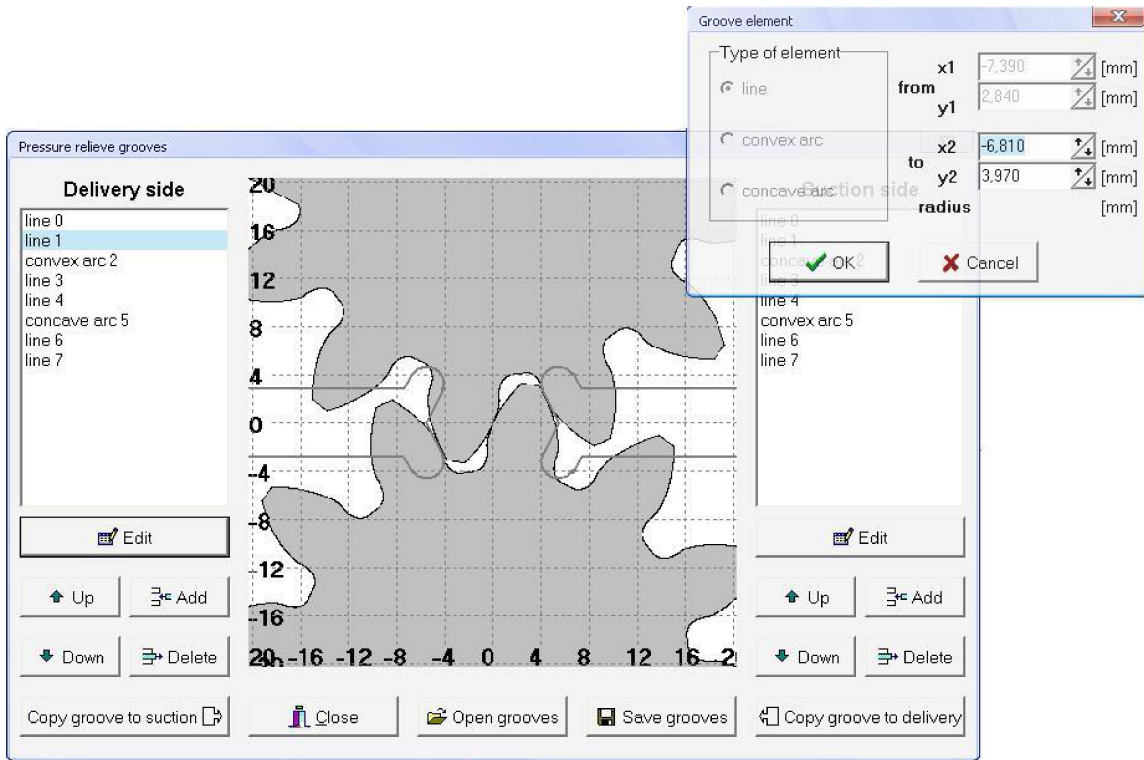

Fig. 4. Modeling of the discharging grooves.

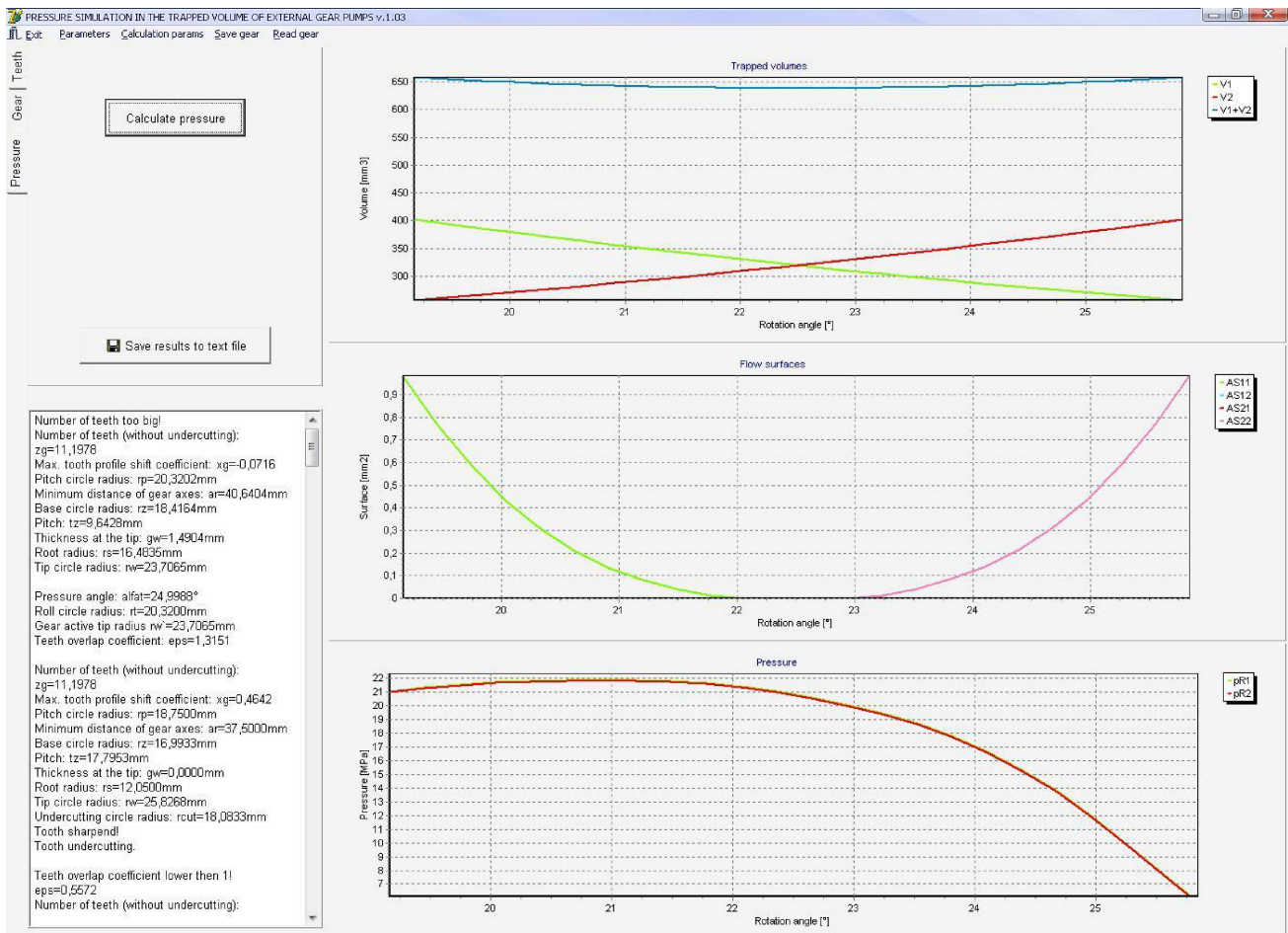

Fig. 5. Pressure – the Third Module of the Computer Program.

Pressure release grooves are modeled using geometrical elements such as: lines, convex arcs and concave arcs. The user determines the start and end position of each element (and the radius for arcs). In this way even the complex and unsymmetrical shapes of grooves can be modeled. The grooves on the suction and delivery side are defined separately (Fig. 4).

The third module of the program *Pressure* is to obtain plots (Fig. 5) of:

- inter teeth volumes magnitude,
- flow surfaces (surfaces between the discharging grooves and the inter teeth volume),
- pressure in both inter teeth volumes.

3. Experimental investigations

The experimental investigations has been carried out for the Pump PGP 620 from Parker Hannifin.

The piezoelectric pressure transducers has been mounted inside both gears (Fig. 6). The signals from the transducers are leading from the gears through the endings on both wheels to HBM signal transmission devices (Fig. 7) and to the data acquisition system.

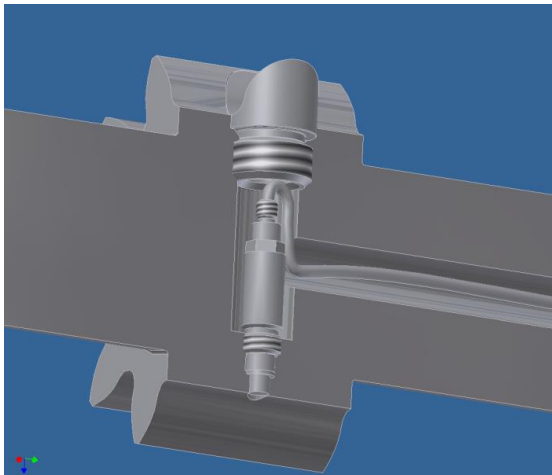

Fig. 6. The pressure sensor inside the gear.

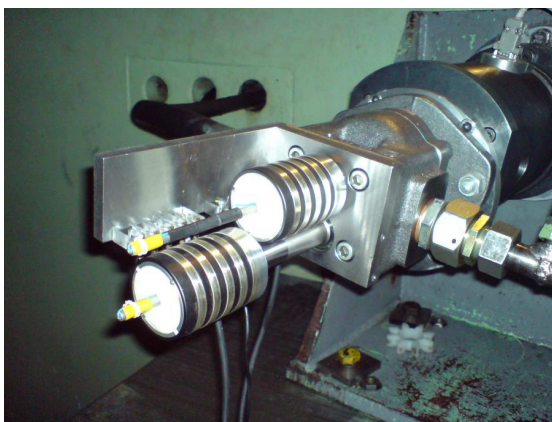
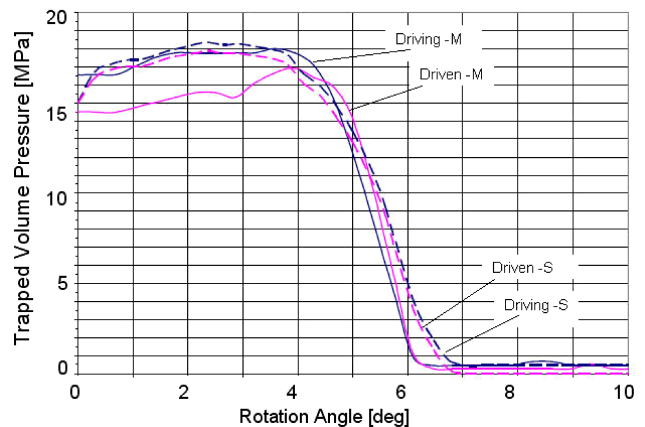

Fig. 7. Pump PGP 620 on the test bench (Wrocław University of Technology).

The results from measurement and its comparison with the simulation has been shown on the Fig. 8.

a) $p = 15 \text{ MPa}$, $n = 1500 \text{ rpm}$



b) $p = 15 \text{ MPa}$, $n = 2000 \text{ rpm}$

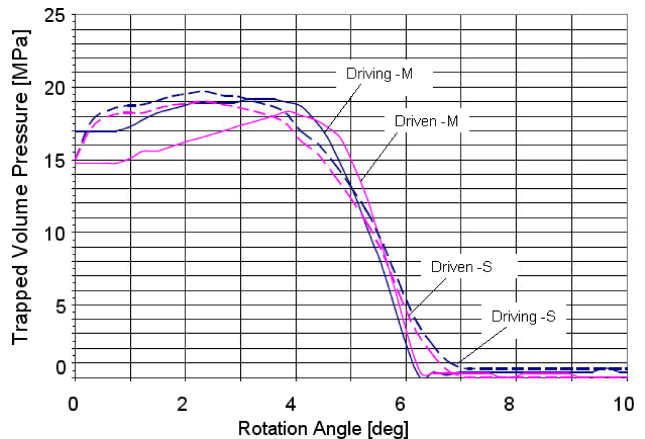

Fig. 8. Comparison between and simulated pressure build down: M – measurement, S – simulation.

Depending on the operational parameters of the pump the differences between both gears has been observed. The simulated pressure build down courses were slightly longer as the measured. This is caused due to the variable leakages between the inter teeth volume and suction side of the pump.

4. Additional volume – the new method of noise reduction in external gear pumps

The inter teeth volume between the teeth is the only volume, which is decompressed during the pressure build down process and it is extremely small. It is usually much smaller as in all other fluid power pumps. The pressure build down processes occur therefore in the respectively shortest time in comparison with other pumps. With the joining of additional volume to the inter teeth volume it is possible to lengthen the pressure build down processes and to reduce the pressure

overdue in external gear pumps. The Eq. (1) in case of connection between inter teeth and additional volume is following:

$$\frac{dp_{Ri}}{dt} = \frac{1}{\kappa \cdot (V_{Ri} + V_{add})} \left(Q_{Ri} - A_{Si} \cdot \alpha_D \text{sign} \sqrt{\frac{p_{Ri} - p_b}{\rho}} - A_{Si} \cdot \alpha_D \text{sign} \sqrt{\frac{p_{Ri} - p_{Si}}{\rho}} - Q_{RS} - Q_{Li} \right). \quad (2)$$

In Fig. 9 the scheme of the joining of an additional volume has been shown. The additional volume can be adjusted to the pressure changes inside the inter teeth volume.

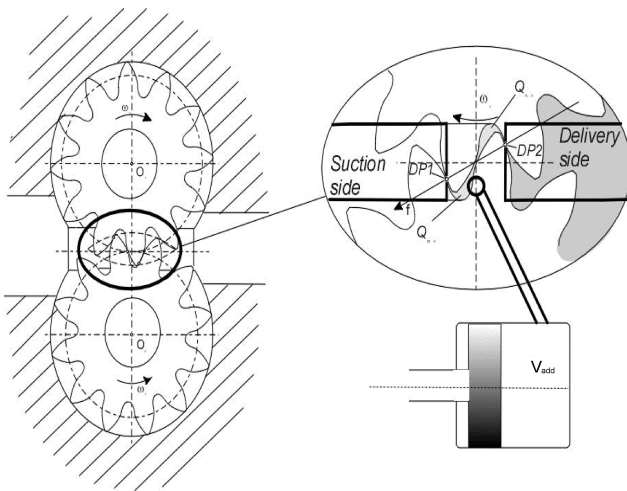

Fig. 9. Scheme of an additional volume in the external gear pump.

In Fig. 10 the results of simulation for different additional volumes has been shown. It is to include, that the time for pressure build down process is limited with the time of double teeth contact i.e. teeth overlap coefficient.

From the diagrams on the Fig. 11 it is to see, that the additional volume has also a positive influence on pressure overdue in the inter teeth volume during the compression phase. With the increasing of the additional volume the pressure overdue in the inter teeth volume is smaller.

The connection of additional volume to the inter teeth volume on example of the pump PGP620 has been shown on Fig. 12. For pumps with the pressure balance plate there is a sealed connection between the plate and the additional volume required. For pump with sliding bearings the connection between the inter teeth volume and the additional volume may occurs without sealing connection and is much easier. During the investigations an adjustable additional volume with moveable piston has been used. Such solution al-

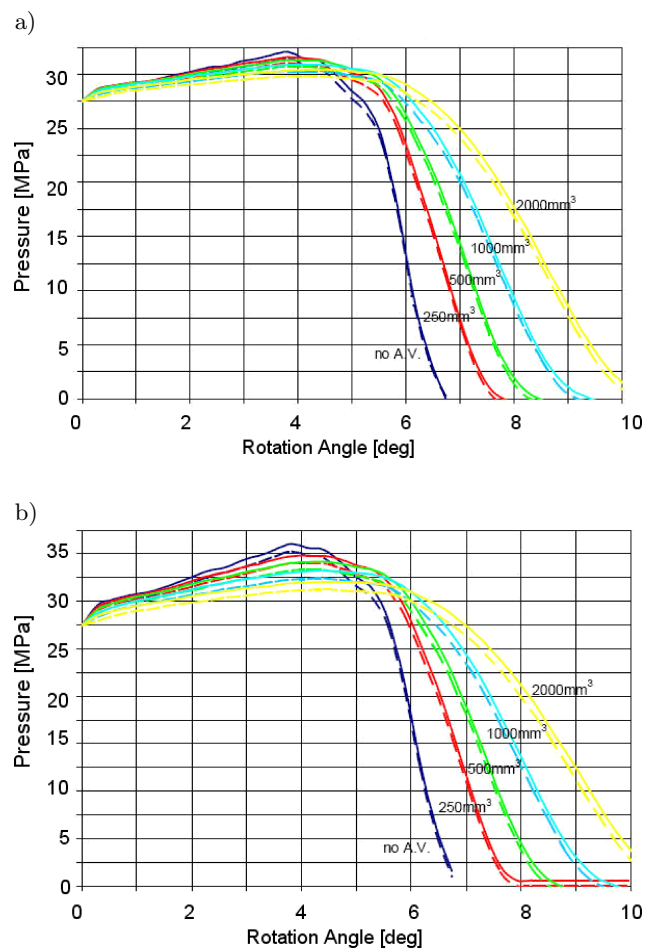

Fig. 10. Comparison of the inter teeth volume pressure with use of different value of the additional volume a) for 1500 rpm and 275 bar, b) for 2000 rpm and 275 bar.

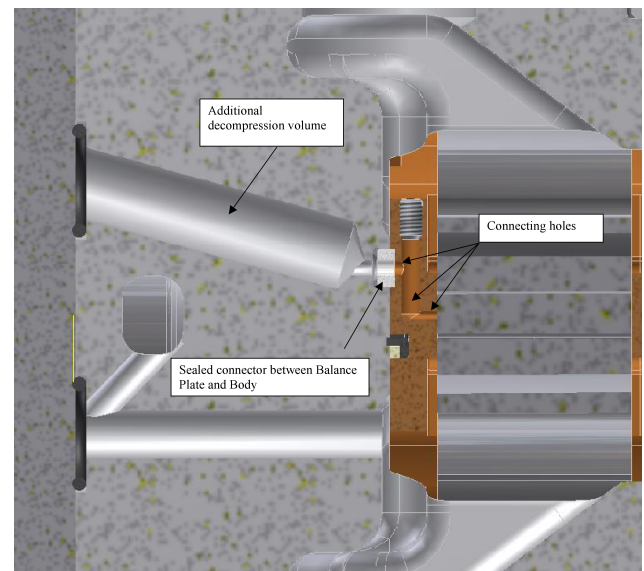

Fig. 11. Additional decompression volume in the pump PGP620.

lows an optimal adjustment of the additional volume to the pump working parameters.

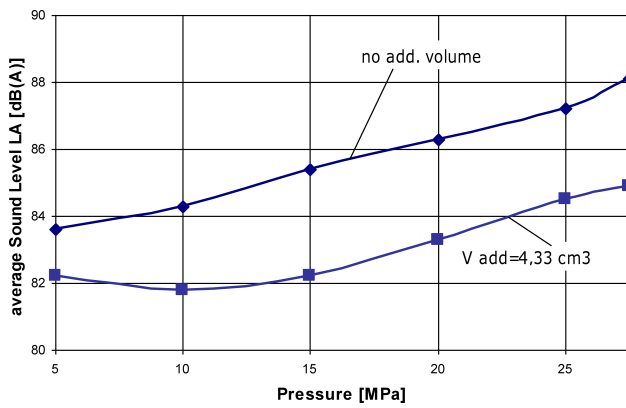

Fig. 12. Noise reduction due to the additional volume at $n = 2000$ rpm.

5. Conclusions

It has been stated that the connection of an additional volume to the inter teeth volume has a positive influence on the pressure processes in the external gear pumps. The additional volume joined to the inter teeth volume lead to the elongation of pressure build down processes and to the reduction of pressure overdue. The value of an additional volume can be established with the simulation method. With the new

method presented in this paper a significant noise reduction of gear pumps can be achieved.

References

1. CASOLI P., VACCA A., FRANZOLI G. (2005), *A numerical model for the simulation of external gear pump*, Proc. of 6 th JFPS Int. Symposium on Fluid Power, TSKUBA, Nov.
2. EATON M., KEOGH P.S., EDGE K.A. (2006), *The modelling, prediction and experimentalevaluation of gear pump meshing pressures with particular reference to aero-engine fuel pumps*, Proc. I. MechE, Vol 220, Part I: Systems and control Engineering.
3. FIEBIG W. (1997), *Schwingungs-und Geraeuschverhalten der Verdraenger-pumpen und hydraulischen Systeme*, Habilitationsschrift, University of Stuttgart, Germany, 2000, Oelhydraulik+Pneumatik O+P, No. 5 and 8.
4. MANRING N., KASARAGADDA S. (2003), *The theoretical flow ripple of an external gear pump*, Trans. of ASME, Vol. 125.
5. ZADRIN B., PALTRINEIERI F., BORCHI M., MILANI M. (2004), *About the prediction of pressure variation in the inter-teeth volumes of external gear pumps*, 3rd FPNI-PhD Symposium on Fluid Power, Spain, June.